

Vegetable Slicer

TR260 Vegetable Slicer - 2 Speed - with lever hopper on stand

ITEM # _____

MODEL # _____

NAME # _____

SIS # _____

AIA # _____

603281 (TR260FL2VS)

 Vegetable slicer, flat panel,
 2 speed on stand -
 380-415/3/50

Short Form Specification

Item No. _____

Universal vegetable slicer to serve 300 up to 1000 settings for table service and up to 4000 settings for catering service. 2 speeds (330/660 rpm). 2000W self-braking motor. Stainless steel motor housing and aluminium basement. "No volt release" safety device. Touch button control panel with on/off, speed selection and pulse function. Cutting disc diam. 300mm. Supplied with lever-operated hopper and mobile stainless steel support that incorporates a disc storage rack (discs not included). The touch button control panel has IP65 protection with low voltage level.

Main Features

- Continuous feed model.
- Large round (long vegetable) and large half moon feed hoppers.
- "No volt release" safety device.
- Delivered with:
 - Lever operated hopper and a mobile stainless steel support that incorporates a disc storage rack (discs not included)
- Complete selection of blades and dicing grids available (diameter 300 mm).
- Magnetic safety system and motor brake. Prevents machine from running when lever swings away or is open.
- Vegetable slicer with slicing, grating, shredding (julienne) as well as dicing and French fries cutting capability.
- Available as option a long vegetable accessory to fit in the lever operated hopper converting it into a long vegetable hopper (3 cylindrical hoppers: 50, 59,5, 70 mm diameter)
- Available upon request:
 - Automatic cylindrical hopper (dia=280 mm), long vegetable hopper (3 tubes) and cabbage hopper.

Construction

- Power: 2000 watts.
- 2 speed: 330-660 rpm.
- Stainless steel motor housing with aluminum basement and hoppers.

Included Accessories

- 1 of Feed tray to be combined with cabbage hopper and long vegetable hopper PNC 650036
- 1 of Stainless steel mobile stand with 4 wheels (2 fixed and 2 pivoting with brake). Height: 730 mm PNC 653017
- 1 of Lever-operated hopper for TR260 (including feed tray) PNC 653036
- 1 of Stainless steel disc rack for 300 dia. discs PNC 653212

APPROVAL: _____

Vegetable Slicer

TR260 Vegetable Slicer - 2 Speed - with lever hopper on stand

Front

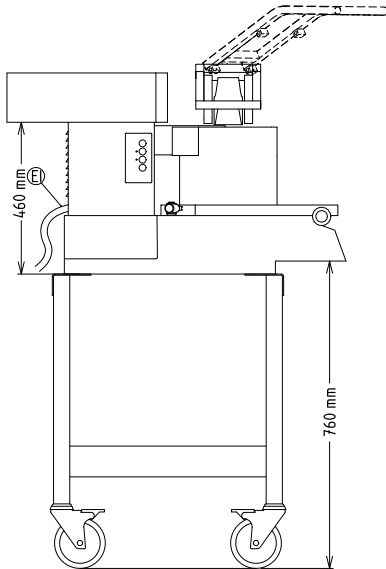

Electric

Supply voltage:	380-415 V/3 ph/50 Hz
Electrical power, max:	2 kW
Total Watts:	2 kW

Capacity:

Performance (up to):	700 kg/hour
----------------------	-------------

Key Information:

External dimensions, Width:	610 mm
External dimensions, Depth:	830 mm
External dimensions, Height:	1400 mm

Side

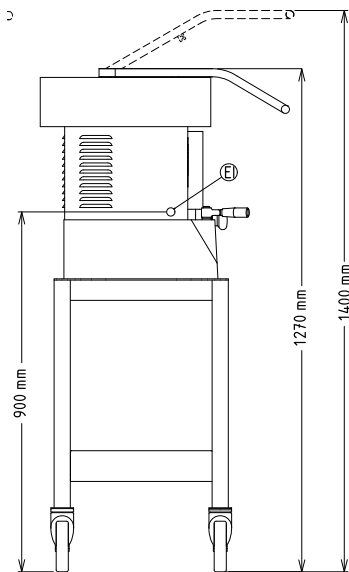

EI = Electrical inlet (power)

Top

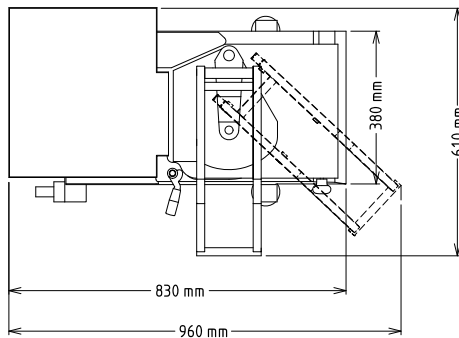

Vegetable Slicer
 TR260 Vegetable Slicer - 2 Speed - with lever hopper on stand

The company reserves the right to make modifications to the products without prior notice. All information correct at time of printing.

2025.07.24